

# BENDING MACHINES SPB 6-20 MILLENNIUM SERIES

CE Approved

For bending pipe from 6" through 20"



## AVAILABLE ENGINES

ENGINE	CATERPILLAR*	PERKINS	DEUTZ
Net flywheel power (DIN 6271)	42 HP	49 HP	41 HP
Model	C2.2	404D-22T	F3L 1011F Whisper
Governed speed	2,600 rpm	2,200 rpm	2,500 rpm
Number of cylinders	4	4	4
Displacement	2.2 Liters	2.18 Liters	1.366 Liters
Bore x stroke	84 X 100 mm	88 x 90 mm	91 x 105 mm
Sound proofing type	yes	yes	yes

\* Default engine

## SHIPPING WEIGHT AND DIMENSIONS

<b>Shipping Length</b>	161.4" (4,100 mm)
<b>Shipping Width</b>	81.9" (2,080 mm)
<b>Shipping Height</b>	74.8" (1,900 mm)
<b>Shipping Net Weight (Complete)</b>	14,110 lb / 6,400 Kg
<b>Operating Weight</b>	14,110 lb / 6,400 Kg
<b>Tires Pneumatic Tires Tubeless</b>	115/80-15.3
<b>Hydraulic System Max. Operating Pressure</b>	3,480 p.s.i. / 240 bar
<b>Extra hydraulic control valves</b>	2

## A New Machine For The New Millennium: SPB 6-20 Millennium Series

The renewed pipe bending machine SPB 6-20 belongs to the "Millennium Series" fleet, which is the new generation of SUPERIOR pipe benders. Despite its simplicity this machine guarantees high performance in terms of speed and push.

The frame is made of high quality steel, and the parts mostly subject to stresses have been ribbed and boxed to ensure maximum resistance, though keeping the machine weight as light as possible.

The hydraulic system has 5 spools; the fifth spool may be used to control the hydraulic mandrel, if fitted. The separate valves

enable the operator to set the mandrel pressure independently from the machine.

The hydraulic cylinders are sized in such a way that they can operate with pressures exceeding 300 bar.

The diesel engine is in a fully insulated and hinged compartment, which swings open and enables the operator to gain access to the engine for maintenance purposes. The SPB 6-20 Millennium Series is installed on rubber wheels, which make its travel easy on any job site, although it is undoubtedly the best solution, especially in small- and medium-sized projects.

## SPECIFICATIONS



### HYDRAULIC SYSTEM

Type	Casappa Gear Type
Maximum oil flow	24 U.S. gal/min / 90 lt/min
Pressure	3,480 p.s.i. / 240 bar



### CONTROLS

Type	1.2" 5 Section
Control	Manual



### ELECTRIC SYSTEM

Voltage	12 V
Batteries in series, maintenance free	1
Total rating	100 Amp/hr
Alternator	30 Amperes
Starter	4 kW



### WINCH

Type	Hydraulic drive
Motor	Orbital type
Line-pull	6,615 lb / 3,000 daN
Cable diameter	1/2" / 12 mm
Working pressure	1,990 p.s.i. / 140 bar
Speed at first layer	12.1 ft/min / 3.7 mt/min



### TIRES

Type	Tubeless
Size	115/80 - 15.3
Gauge	1,750 mm
Parking brake	Drum type



### CAPACITIES

Fuel tank	60 liters / 16 U.S. gal
Hydraulic system	120 liters / 32 U.S. gal

# BENDING MACHINES SPB 6-20 MILLENNIUM SERIES

## SPECIFICATIONS

Cylinder	Two Out-Board	Two In-Board	One Pin-Up
Bore	7.8" / 200 mm	7" / 180 mm	5.1" / 130 mm
Stroke	12.4" / 315 mm	6" / 150 mm	29.5" / 750 mm
Max. Push	332,275 lb / 150,720 kg	228,439 lb / 103,620 kg	70,194 lb / 31,840 kg

Auxiliary Quick Disconnect	Size	Maximum Flow	Adj. Pressure
Aux-1	1/2"	24 U.S. gal/min / 90 liters/min	2,844 p.s.i. / 200 bar
Aux-2	3/8"	24 U.S. gal/min / 90 liters/min	2,844 p.s.i. / 200 bar

## BENDING DATA (U.S.)

Pipe O.D. inch	Maximum Wall Thickness By Grade (Inch)							Recommended Bend		
	X52	X56	X60	X65	X70	X80	X100	Degree per Arc Foot	Radius Feet	Max Degree Per 40 Feet
6	2	2	2	2	2	2	2	4.41	13	132.30
8	2	2	2	2	2	2	2	3.82	15	114.60
10	2	2	2	2	2	2	2	2.86	20	85.80
12	2	2	2	2	2	2	1-7/16	2.30	25	69.00
14	2	2	1-3/4	1-5/8	1-7/16	1-3/16	7/8	1.70	34	51.00
16	1-3/8	1-1/4	1-1/8	1-1/16	15/16	13/16	5/8	1.51	38	45.30
18	1	7/8	13/16	3/4	11/16	9/16	7/16	1.10	52	33.00
20	3/4	11/16	5/8	9/16	1/2	7/16	3/8	0.83	69	24.90

## BENDING DATA (METRIC)

Pipe O.D. inch/mm	Maximum Wall Thickness By Grade (Inch)							Recommended Bend		
	X52	X56	X60	X65	X70	X80	X100	Ratio Radius: O.D.	Radius Meter	Max Degree Per 12 Meters
6 / 168	50.80	50.80	50.80	50.80	50.80	50.80	50.80	4.41	13	132.30
8 / 219	50.80	50.80	50.80	50.80	50.80	50.80	50.80	3.82	15	114.60
10 / 273	50.80	50.80	50.80	50.80	50.80	50.80	50.80	2.86	20	85.80
12 / 324	50.80	50.80	50.80	50.80	50.80	50.80	36.52	2.30	25	69.00
14 / 355.6	50.80	50.80	44.45	41.28	36.52	30.17	22.23	29.1	10.36	51.00
16 / 406.4	34.93	31.75	28.58	26.99	23.82	20.64	15.88	28.5	11.58	45.30
18 / 457.2	25.40	22.23	20.64	19.05	17.47	14.29	11.12	34.7	15.85	33.00
20 / 508	19.05	17.47	15.88	14.29	12.70	11.12	9.53	41.4	21.03	24.90

## DIMENSIONS

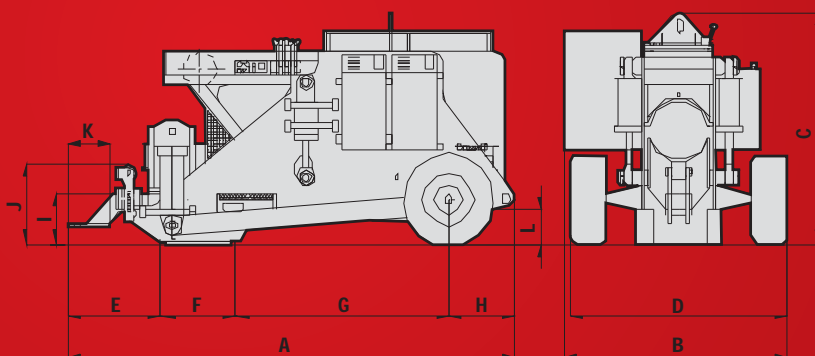

A	4.1 m / 13.5'
B	3.03 m / 6.8'
C	1.9 m / 6.25'
D	2.05 m / 6.7'
E	87 cm / 2.85'
F	68 cm / 2.25'
G	1.94 m / 6.4'
H	61 cm / 2'
I	45.5 cm / 1.5'
J	71.5 cm / 2.4'
K	40 cm / 1.3'
L	30 cm / 1'



## CONTACT INFORMATION

### **Main office – General inquiries SUPERIOR Manufacturing**

16031 East Freeway  
Channelview, TX 77530  
U.S.A.  
Phone 281.457.4400  
Fax 281.452.5455  
U.S. Toll Free 800.383.2666  
Intl. Toll Free 800.9675.3948  
pipeline@wwmach.com  
www.worldwidemachinery.com

### **Italy office SUPERIOR Manufacturing**

Via Roma, 18  
San Pancrazio, Parma  
Italy

**Evan Greenberg**  
Vice-President of Intl. Operations

### **Worldwide offices Europe and Australia**

Juergen Hafemann  
Phone +49.0.231.963.3073 Germany  
Phone +61.0.400.144.432 Australia  
pipelinece@wwmach.com

### **India**

Abhishek Bhotika  
Phone +91.11.414.59230  
pipelineind@wwmach.com

### **Africa**

Evan Greenberg  
Phone +1.281.452.5800  
pipeline@wwmach.com

### **Russia, China and the Middle East**

Sergio Braoude  
Phone +39.349.198.1281 Italy  
Phone +7.495.507.4827 Russia  
fsupipeline@wwmach.com

### **Latin America**

Salvador Villasana  
Phone +52.81.8.394.0160  
pipelinesa@wwmach.com

### **North America**

Rick Layh  
Phone +1.281.457.4400  
pipelinena@wwmach.com

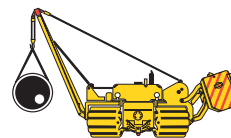

**WORLDWIDE  
MACHINERY  
PIPELINE DIVISION**

 **SUPERIOR  
MANUFACTURING**

# DISCLAIMER

## DISCLAIMER

The information contained in this brochure is intended to be of a general nature only. The SUPERIOR Manufacturing Company may at any time and from time to time, for technical or other necessary reasons, modify any of the details or specifications of the product described in this brochure. Illustrations do not necessarily show products in standard conditions. The dimensions, weights and capacities shown herein, as well as any conversion data used, are approximate only and are subject to variations within normal manufacturing techniques.